

*** WEIGHT INCLUDES ALL ITEMS EXCEPT RSOD (1200 LB / 563 kg)

SERIES	RETRACTED LENGTH	EXTENDED LENGTH	G inches (cm)	DRY/WT LB (kg)	WITH OIL/WT*** LB (kg)
969A*	27' 6"	69' 2"	87 (221)	19,420 (8809)	20,000 (9072)
990A*	27' 6"	90' 6"	94 (238)	21,025 (9536)	21,610 (9802)
9103A**	30' 9"	102' 10"	106 (269)	22,150 (10 047)	22,735 (10 312)

* INCLUDES SUBBASE FOR 20' BED
 ** INCLUDES SUBBASE FOR 22' BED

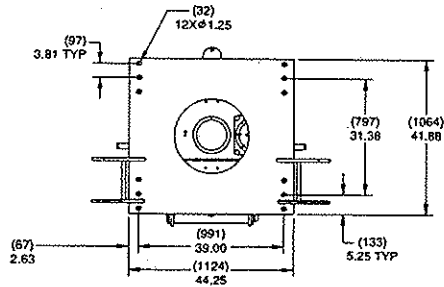

BOTTOM VIEW
 SOME COMPONENTS
 REMOVED FOR CLARITY

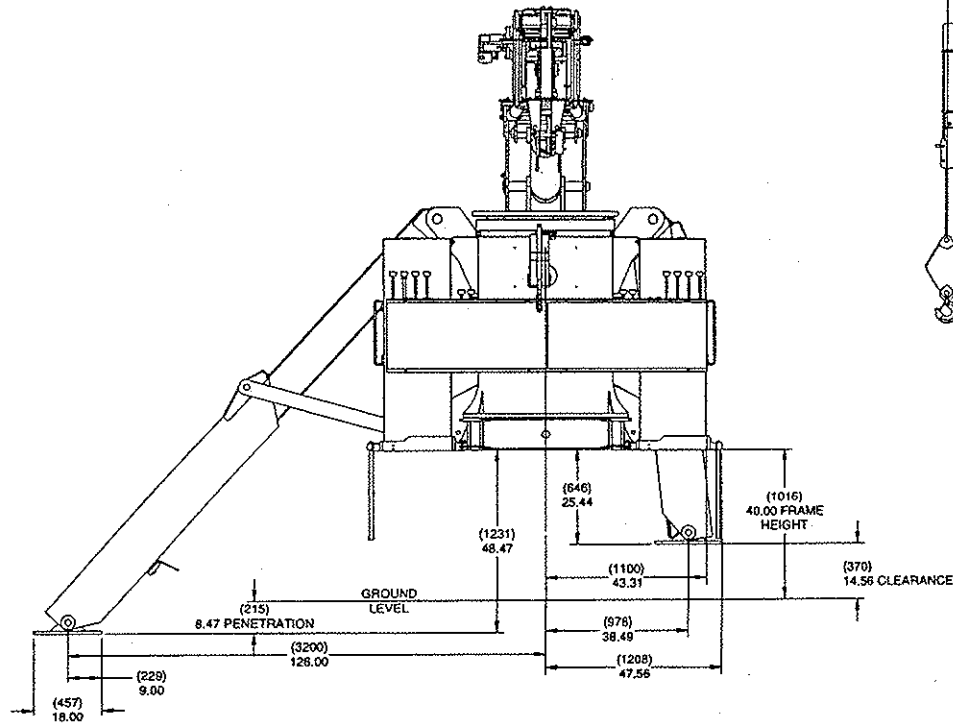

SPECIFICATIONS

(DIMENSIONAL SPECIFICATIONS)

NOTES:

MAX RATED LOAD MOMENT 4,838,000 IN/LB (546 620 N-m)
 THRUST AT MAX RATED LOAD MOMENT 24,100 LB (10 931 Kg)
 MAX RATED ROTATIONAL TORQUE 429,000 IN/LB (48 470 N-m)
 MAXIMUM THRUST 74,200 LB (33 656 Kg)
 DIMENSIONS IN () ARE IN mm UNLESS OTHERWISE SPECIFIED

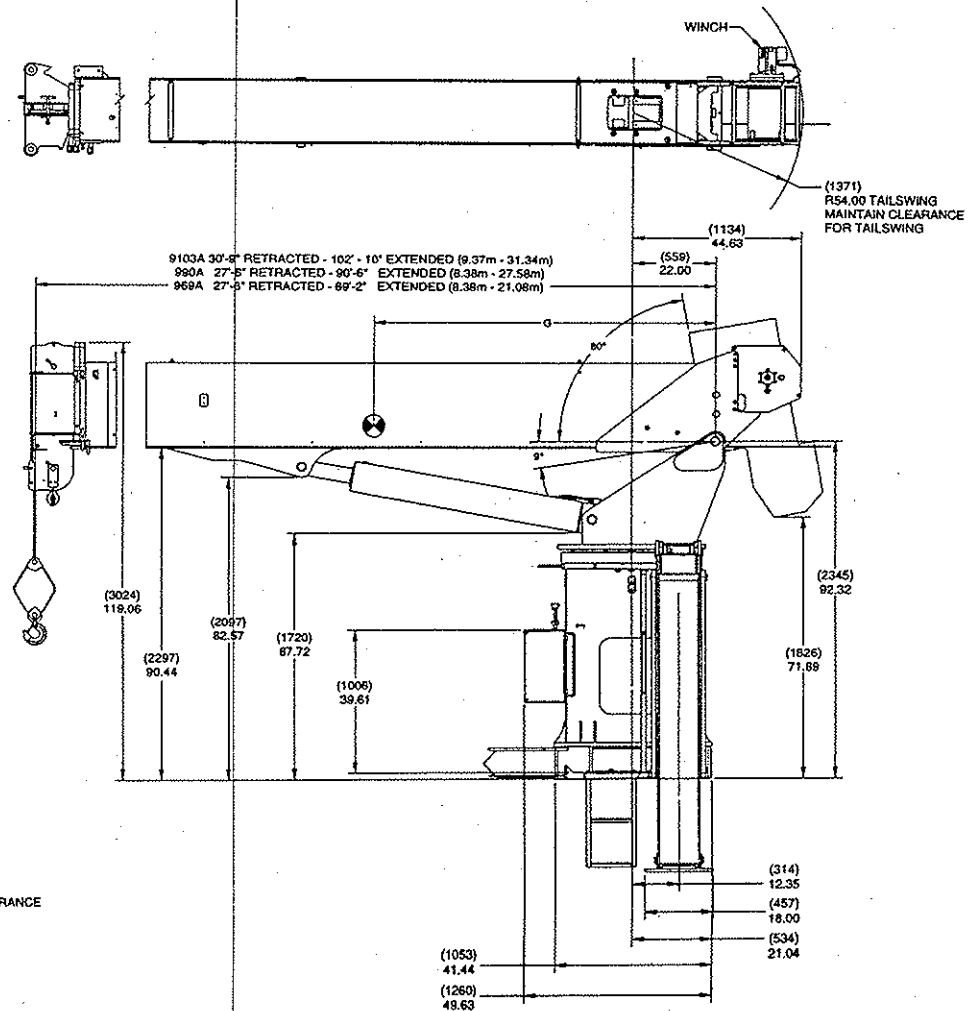

*** WEIGHT INCLUDES ALL ITEMS EXCEPT RSOD (1200 LB / 563 kg) OR ASH (800 LB/363 kg)

SERIES	RETRACTED LENGTH	EXTENDED LENGTH	G Inches (cm)	DRY/WT LB (kg)	WITH OIL/WT*** LB (kg)
969A	27' 6"	69' 2"	77 (196)	18,305 (8310)	18,840 (8553)
990A	27' 6"	90' 6"	84 (213)	19,635 (8914)	20,220 (9180)

ILLUSTRATION DESPCTS BOOM STOWED TO REAR. IN ALL CASES, G IS MEASURED FROM THE PIVOT PIN OF THE BOOM TOWARD THE SHEAVE CASE OF THE BOOM, REGARDLESS OF WHETHER BOOM IS STOWED TO THE FRONT OR REAR.

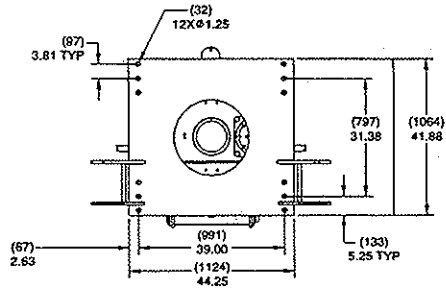

BOTTOM VIEW
SOME COMPONENTS
REMOVED FOR CLARITY

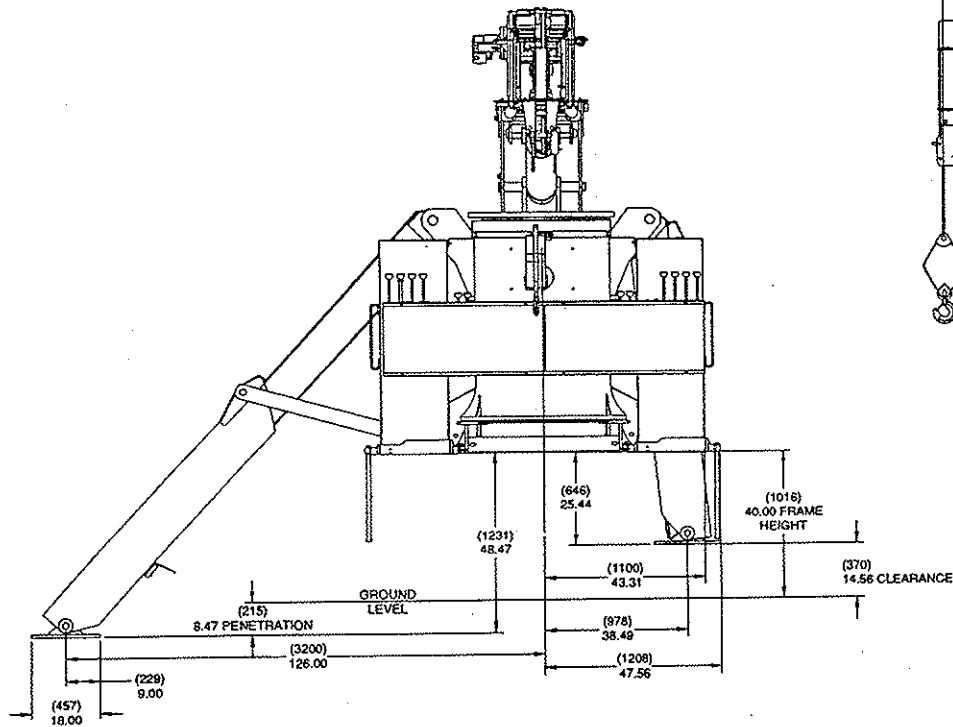

SPECIFICATIONS (DIMENSIONAL SPECIFICATIONS) TRACTOR MOUNT

NOTES:

MAX RATED LOAD MOMENT 4,838,000 IN/LB (546 620 N-m)
THRUST AT MAX RATED LOAD MOMENT 24,100 LB (10 931 Kg)
MAX RATED ROTATIONAL TORQUE 429,000 IN/LB (48 470 N-m)
MAXIMUM THRUST 74,200 LB (33 656 Kg)
DIMENSIONS IN () ARE IN mm UNLESS OTHERWISE SPECIFIED

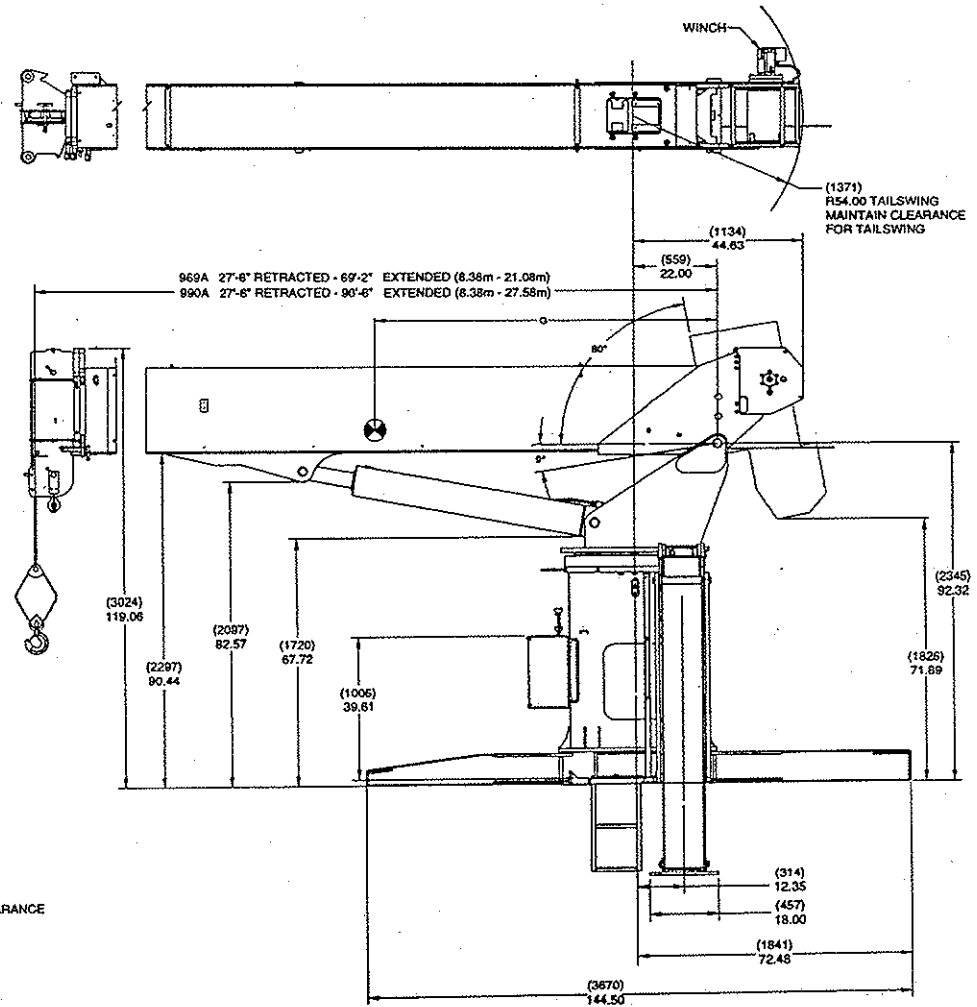

NATIONAL CRANE CORPORATION

87725

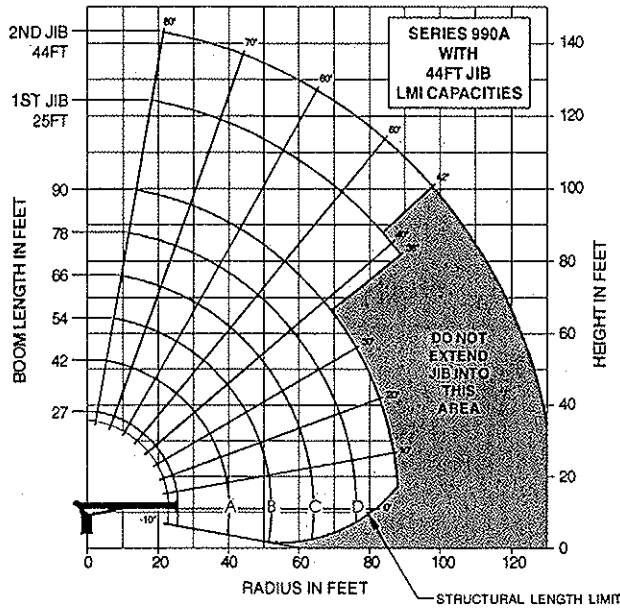

NOTE:

1. Operate with jib by radius when main boom is fully extended. If necessary increase boom angle to maintain loaded radius.
2. Operate with jib by boom angle when main boom is not fully extended. Do not exceed rated jib capacities at any reduced boom lengths.
3. Capacities do not exceed 85% stability.
4. Shaded areas are structurally limited capacities.

LMI OPERATING CODE SWITCH	
SWITCH POSITION (REF #17)	OPERATING MODE
01	MAIN BOOM - NO JIB STOWED
02	MAIN BOOM - JIB STOWED
03	25 FT TELE JIB
04	44 FT TELE JIB
11	MAN BASKET ON MAIN BOOM
12	MAN BASKET ON 25 FT TELE JIB
13	MAN BASKET ON 44 FT TELE JIB

LOAD RATINGS

LOAD RADIUS (FEET)	LOADED BOOM ANGLE	27FT BOOM (lb)	LOADED BOOM ANGLE	A 42FT BOOM (lb)	LOADED BOOM ANGLE	B 54FT BOOM (lb)	LOADED BOOM ANGLE	C 66FT BOOM (lb)	LOADED BOOM ANGLE	D 78FT BOOM (lb)	LOADED BOOM ANGLE	80FT BOOM (lb)	LOAD RADIUS (FEET)	LOADED BOOM ANGLE	25FT JIB (lb)	LOADED BOOM ANGLE	44FT JIB (lb)
5	77	52,000											30	75	4,850	77.5	3,300
8	70.5	35,900											35	72.5	4,350	75	3,250
10	66	30,600	75	26,900	79	25,900							40	70	3,900	73	3,200
12	60.5	25,900	72	23,000	77	23,600							45	67	3,500	71	3,050
14	55.5	21,600	69	20,100	74	20,100	78	18,100					50	64.5	3,150	69	2,750
16	50	19,300	66	17,800	72.5	16,700	76	15,700	78.5	14,700			55	61.5	2,800	66.5	2,400
20	38.5	14,800	59.5	13,600	67.5	13,500	72.5	13,600	75.5	12,500	78	11,500	60	59	2,500	64	2,150
25			51.5	11,300	61.5	11,000	68	11,000	71.5	10,300	74.5	9,300	65	56	2,200	61.5	1,900
30			41.5	9,050	55	8,900	62.5	9,000	67.5	8,600	71	7,900	70	52.5	1,750	59	1,700
35			30	7,050	48.5	7,350	58	7,200	64	7,150	68	5,700	75	49	1,400	56.5	1,550
40					41	6,100	52.5	6,000	59.5	5,850	64.5	5,850	80	45.5	1,100	54	1,400
45					31.5	4,900	46.5	5,100	55	4,900	61	4,900	85	42	800	51.5	1,250
50					17.5	3,850	40	4,350	50.5	4,250	57	4,250	90	38	550	48	1,000
55							32.5	3,550	45	3,650	53	3,700	95			45	800
60							22	2,650	39.5	3,100	48.5	3,250	100			42	600
65									33	2,550	44	2,800					
70									24.5	1,950	39	2,350					
75									11	1,050	33.5	1,950					
80											26.5	1,550					
85											16.5	950					
	0	6,400	0	3,000	0	1,600	0	700									
ADD TO CAPACITIES WHEN NO JIB STOWED (lb)		700		400		300		200		200		100					

LOADLINE EQUIPMENT DEDUCT (lb)

Downhaul weight _____ 150
 One sheave block _____ 305
 Two sheave block _____ 355
 Three sheave block _____ 575

1 PART LINE	2 PART LINE	3 PART LINE	4 PART LINE	5 PART LINE	6 PART LINE	7 PART LINE
MAX. PULL 7,700 lb	MAX. PULL 15,400 lb	MAX. PULL 23,100 lb	MAX. PULL 30,800 lb	MAX. PULL 38,500 lb	MAX. PULL 46,200 lb	MAX. PULL 52,000 lb

NOTICE

- Do not deadhead line block against boom tip when extending boom.
- Keep at least 3 wraps of loadline on drum at all times.
- Use only 9/16" diameter rotation resistant cable with 38,500 lb breaking strength on this machine.
- Maximum capacity with "burst of speed" is 3,000 lb.







1 PART LINE	2 PART LINE	3 PART LINE	4 PART LINE	5 PART LINE	6 PART LINE	7 PART LINE
						
MAX. PULL 7,700 lb (3492 kg)	MAX. PULL 15,400 lb (6985 kg)	MAX. PULL 23,100 lb (10 477 kg)	MAX. PULL 30,800 lb (13 970 kg)	MAX. PULL 38,500 lb (17 463 kg)	MAX. PULL 46,200 lb (20 955 kg)	MAX. PULL 52,000 lb (23 586 kg)

FIGURE 1

WINCH SYSTEM OPERATION

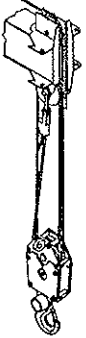
The winch is mounted at the rear of the first section boom. It has capacities totally independent of the rest of the crane and can normally pull more than the crane itself can withstand. Therefore, care must be taken to insure that the load being lifted is within boom rating. To lift some of the heavier loads on the capacity chart, it will be necessary to multiple part reeve the winch block to increase the lifting capacity of the winch (the speed is proportionately slower) and remain in the strength limitations of the winch and wire rope.

On a crane equipped with an LMI system, the maximum allowable load indicated on the LMI display, when a single part of line is selected, will exceed the maximum pull value listed on the parts of line chart provided on the crane's capacity chart. The higher maximum allowable load is provided to allow full winch performance, to the stated single part of line maximum pull value provided on the crane's capacity chart, without the LMI system activating the kick-out function. **Never lift loads that exceed the maximum pull value listed on the crane's capacity chart for the parts of line reeved.**

USING MULTIPLE PART LINES

The winch load rating chart on each machine provides the information for pull limitations on the winch with various applicable part reevings. These ratings are based on providing the proper operating safety factor on the wire rope supplied with the machine. Therefore, any replacement rope must meet the rope specification sections of this manual (Figure 1).

GENERAL RULES WHEN OPERATING WINCH

1. Always operate the winch control to payout the loadline while extending the boom. This will maintain clearance between the boom tip and loadline hook.
2. Do not rely on anti-two-block system to eliminate two blocking. Use the system as a backup to safe

operation.

3. Make certain the winch cable is not twisted or kinked and that cable is properly seated on the drum and in the sheaves.
4. Before lifting a load, always make certain that three full wraps of rope will remain on the drum at all times throughout the lift.
5. When lifting a load approaching the rated winch load, raise the load a few inches and return the control to neutral to determine if the brake is working properly.
6. Do not drag loads in any direction with the winch
7. Never attempt to lift loads which are not loose and free, i.e. frozen down material or poles out of ground.
8. Maintain tension on the loadline at all times to prevent the cable from becoming twisted or kinked or improperly seated on the winch drum or sheaves.

LIFTING THE LOAD

After the vehicle and crane have been properly set up and it has been determined the load to be lifted is within the ratings of the crane and winch reeving system, again check the work area for electric power lines and other obstructions so that proper clearances can be maintained. (See Safety Rules.) If load is not visible to operator throughout lift, a person must be appointed to use hand signals as shown on the last page of this section. Proceed with lifting the load.

1. Rotate, extend or move up or down until boom tip is directly over the load.
2. The crane is normally equipped with a rotation stop. It is important that you be aware of the position of the stop before lifting in order to assure maximum rotation and prevent excessive handling of the load.
3. During operations, the controls should always be metered when beginning or terminating movement to prevent sudden starting or stopping, which imposes undue shock loads on the equipment. This is especially true when handling